

# SR-26

## DUAL TIME CODE DISTRIBUTOR

Operation Manual

**BRAINSTORM ELECTRONICS, INC.**

*distributed exclusively through:*

**AUDIO INTERVISUAL DESIGN**

1155 N. La Brea Avenue, West Hollywood, CA 90038

Tel: 323 - 845 - 1155 • Fax: 323 - 845 - 1170

[www.aidinc.com](http://www.aidinc.com)



**BRAINSTORM  
ELECTRONICS, INC.**

*...Intelligent Solutions For The Recording Studio*

## Specifications

Configuration: 1x4 + 1x2 or 1x6 (front panel switchable)

Input: Signal: SMPTE/EBU Longitudinal Time Code  
(forward or reverse, play, shuttle & wind)

Impedance: 20K balanced; 10K unbalanced

Level: -30dbU min; +20dbU max

Output: Impedance: 600 balanced; 300 unbalanced

Level: full off to +10dbU balanced; to +4dbU unbalanced  
front panel pots adjustable

Waveform: switchable rise time (front panel switch):

25 $\mu$ s (SMPTE), 50 $\mu$ s (EBU), or 1 $\mu$ s (square wave)

Amplitude Distortion: less than 2%

Connectors: XLR Female (2 inputs); Male (6 outputs)

Pins: 3=high; 2=low; 1=ground

Indicators: Red LED: power

Green LED (2): Signal in

Power: 9VAC @ 1A (8.5VAC @ 1.35A wall adapter supplied)

Ground Lift Switch: Isolates chassis ground from signal ground

Dimensions: 19" x 1 3/4" x 4 1/2"

Weight: 2 1/2 lbs (w/o power supply or packing material)

## Introduction

The SR-26 is a high quality reshapener that can recondition very low level or amplitude distorted time code into a properly shaped waveform and distributes it through 6 individually buffered outputs.

The SR-26 houses 2 separate time code reshapers. Reshaper "A" has 4 outputs (1 through 4) and reshaper "B" has 2 (5 and 6). A front panel switch lets you route input "A" into reshaper "B", changing the SR-26 into a single 1x6 distributor.

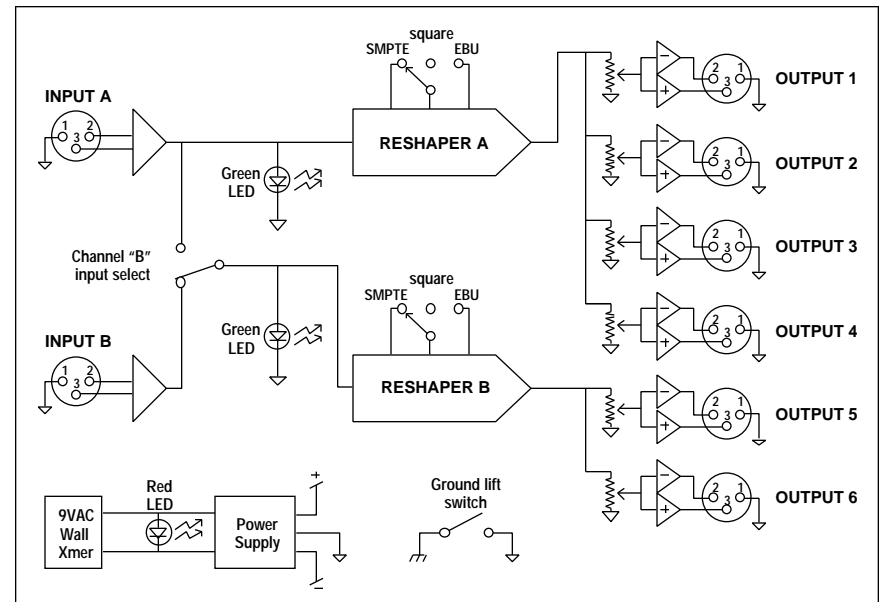

## Table of contents

Installation .....	2
Distributing Time Code .....	4
Reshaping Time Code .....	4
Time Code Level .....	5
Selecting the proper rise time .....	5
Additional Applications .....	6
Problems solved by the SR-26 .....	7
Other Brainstorm products .....	7
Specifications .....	8

## Installation

- ⇒ Time Code Inputs: patch your time code source(s) (i.e.generator or tape machine) into the SR-26 input(s)
- ⇒ Time Code Outputs: patch the outputs of the SR-26 into all appropriate destinations (see page 3).  
*The equipment you connect to the SR-26 can be balanced or unbalanced. See "BALANCED OR UNBALANCED?" below for proper wiring.*
- ⇒ Power: the SR-26 comes with a UL approved 120 VAC to 8.5 VAC power supply. Plug it into the rear panel "Power" Jack.  
*In countries with different power, use a compatible converter. The SR-26 requires 7-10VAC @ ≥.5A.*

## Wiring

### BALANCED OR UNBALANCED?

The SR-26 uses XLR connectors for time code inputs and outputs. XLR Pins are: 1= ground, 2= Low, 3= High. Since time code is bi-phase, a reversal of low & high wires wouldn't cause a problem

The SR-26 works with balanced and unbalanced equipment. It can balance an unbalanced signal or vice-versa. This can eliminate problems due to mismatched impedance and ground loops.

When using unbalanced equipment with the SR-26, wire your cables as described in the diagram below.

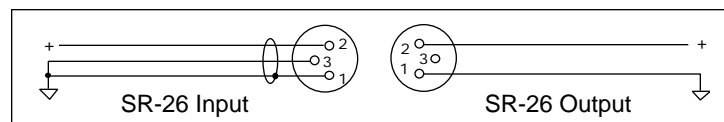

proper unbalanced wiring diagrams

## Typical problems solved by the SR-26

- ⇒ Time code was recorded too low (or the reader threshold is too high);
- ⇒ Glitches or drop outs due to level fluctuations;
- ⇒ Reader equipment is sensitive to improper waveform due to:
  - Distortions induced by cable or inductive load (either ringing or rounding off),
  - Poor reproduction of the recorded time code (especially with VCR's),
  - Elongated rise time at low shuttle speeds,
  - Accentuated peaks at high shuttle speeds;
  - The output of some old generators is distorted and needs reshaping;
  - Reader equipment requires a fast rise time;
- ⇒ One of the destinations is shorting all others through a mult;

## Other time code products available from Brainstorm Electronics, Inc.

### SR-1: THE ULTIMATE TIME CODE REFRESHER

A portable time code resaper with 1 input & 1 output.

### SR-2: TIME CODE RESHAPER W/ FRAME RATE COUNTER

Same unit as the SR-1 with a 4 digit frame rate counter

### SR-15+: TIME CODE DISTRIPALYZER

Combines a 1x5 distributor, a tone stripper and a time code analyzer. The Analyzer identifies the type, stability and frame rate of the incoming time code, monitors its phase with video and reports errors.

## Additional applications

### 1. DUBBING TIME CODE

Re-recording time code by direct transfer is not recommended since the accumulated distortions make it very unreliable. Instead, patch your time code into the SR-26 and record the reshaped output. Set the rise time switch to SMPTE or EBU (as needed) and adjust the output level for optimum recording.

*To minimize cross-talk, do not record time code and audio simultaneously on adjacent tracks. Instead, stripe time code first, then sync up the tape machine(s) and record the audio. While recording the audio, you will erase any time code that may have spilled to adjacent tracks.*

### 2. VARIABLE SPEED RESHAPING

Some variable speed readers are designed to read time code at speeds ranging from 1/50th to 100x playspeed. However, at high or low speeds, many tape machines distort time code so badly that it becomes unreadable. The SR-26 can reshape time code over an even wider range in forward and in reverse.

*For variable speed reshaping, the recorder's playback electronics must be capable of reproducing higher/lower frequencies: SMPTE at 20x playspeed = 48Khz; at 1/100x playspeed = 24Hz.*

*For high speed reshaping, set the rise time switch to square wave so high frequencies don't get filtered out.*

### 3. TIME CODE IN REMOTE TRUCKS

Long cables can induce ringing or rounding off of the signal and render time code unreadable. The SR-26 can drive several hundred feet of cable and remain stable. This makes it ideal for sending time code to or from a remote truck.

## Re-shaping vs. re-generating

Many problems are caused by distorted time code and most of them can be solved by reshaping the time code. However the SR-26 will not correct bit or timing errors nor will it regenerate new time code if the incoming signal drops out.

*The reshapener eliminates amplitude distortions. To repair timing distortions or drop-outs, use a time code generator.*

## CONNECTING THE SR-26 TO YOUR STUDIO

There are many different ways of connecting your SR-26 to your studio. These will vary according to the equipment you have and the type of set up you use. Following are some set up examples:

*In this set up, there are two tape machines. Channel "A" reshapes and distributes time code from the master machine and channel "B" from the slave.*

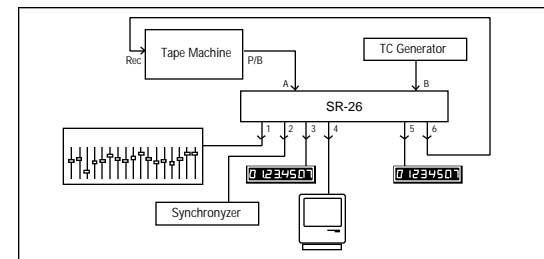
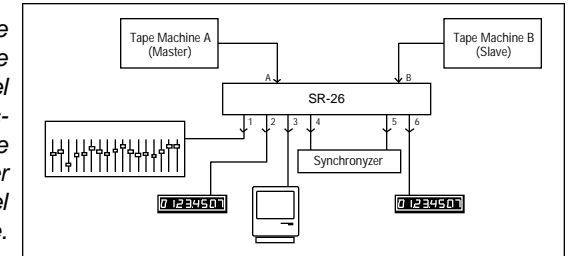

*Here, channel "B" is used to send time code to the tape machine when stripping it; channel "A" distributes the master time code during playback.*

*When more than 4 time code outputs are needed, the front panel switch can change the SR-26 into a 1x6 time code distributor.*

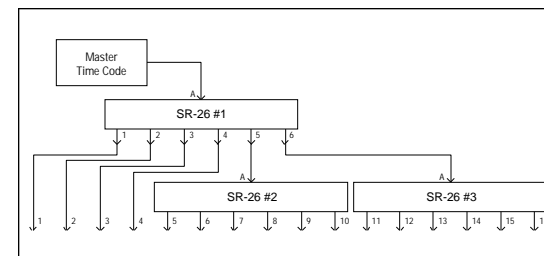
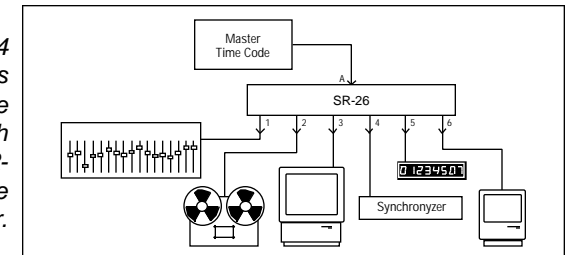

*If more than 6 outputs are needed, several SR-26's can be "daisy-chained". In this set up, 3 SR-26's provide a total of 16 outputs (see note on page 5 regarding rise time setting).*

## Distributing Time Code

In today's studio, more and more pieces of equipment rely on time code for precise timing: console automations, sequencers, DAW's, readers, synchronizers, editors etc...

Simply multing a single output of a tape machine or of a generator is not recommended because it can cause serious problems:

- Multing a single output ties the destinations' inputs together. If one piece of gear is miswired and creates a short, all destinations will be affected. This could easily happen since, until recently, there was no universal standard regarding XLR pins 2 and 3.
- Heavy loading from high capacitance cables and/or low impedance loads can cause source distortions and instability.

The SR-26 eliminates these problems by providing 6 individually buffered and balanced outputs.

In addition to distributing time code, the SR-26 also reshapes it.

## Reshaping Time Code

When time code comes off a tape machine (especially VCR's), it usually has improper rise/fall times, leading edge peaking and different amplitude levels on "one's" and "zero's" (see diagrams below). This is due to the fact that analog tape machines were not designed to record a signal that is basically digital.

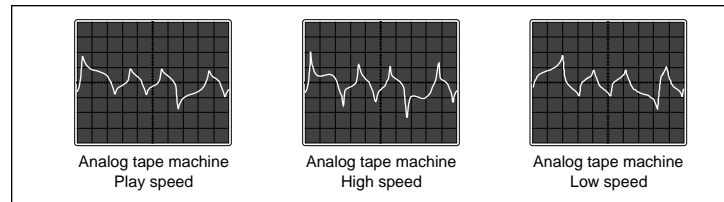

This can make the time code difficult or sometimes impossible to read. The SR-26 eliminates these amplitude distortions by reshaping the code to its original SMPTE or EBU specifications.

## TIME CODE LEVEL

Some readers operate best when time code is at a specific level. The problem is that this is not necessarily the level at which it was recorded. Also, if this level fluctuates or drops below the reader's threshold, time code can become unreadable.

With the SR-26, you can adjust each output level individually so that optimum levels can be sent to each reader. These levels will remain constant regardless of input level fluctuations.

Since the SR-26's input threshold is lower than many readers (better than -30dB), it can reshape and recover time code that many synchronizers can't read.

## SELECTING THE PROPER RISE TIME

Per SMPTE and EBU specifications, the rise time limiting is used to minimize crosstalk from time code into audio. A longer rise time removes more high frequency components from its waveform. However some equipment may not be able to read time code if its rise time is too long.

The SR-26 has 3 preset rise times for its output waveform: 25  $\mu$ sec (SMPTE), 1  $\mu$ sec (square wave) and 50  $\mu$ sec (EBU).

*There are 2 rise time switches on the front panel: one for channel A and the other for channel B. The channel B switch controls the waveform of outputs 5 and 6, even when the SR-26 operates as a single 1x6 distributor.*

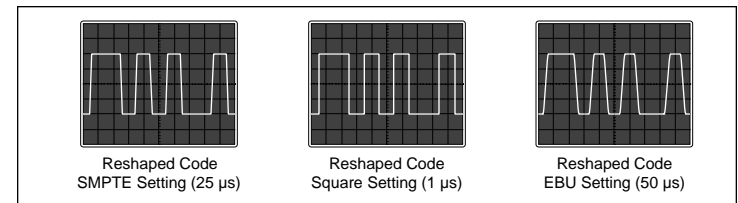
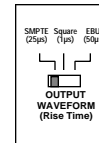

As a general rule, if time code is patched directly into a reader, use the square wave position; but, whenever possible cross-talk problems exist (i.e. in an audio patchbay...) or when recording the reshaped signal, use the SMPTE or EBU setting (as needed).

*NOTE: When daisy-chaining several SR-26 units, set the rise time on the channel(s) feeding the other unit(s) to square wave.*