



The world's most original microphone maker

## CS-2 Compact shotgun mic with long reach and rich, natural tone



- Clear sound without distortion
- 120mm/4.75" long audio tube in standard 250mm/10" mic housing
- Optimum audio capture via Sanken's original rectangular capsule
- High Boost Switch compensates for windscreen frequency attenuation
- Consistent operation in all types of weather
- Supersharpest directivity

### Standard length short shotgun with greater directivity and extended reach

The newest model in Sanken's comprehensive shotgun microphone line offers extended reach in a standard length mic via the company's unique audio tube length and proprietary rectangular diaphragm design. As a result, a rich natural tone is produced throughout the frequency spectrum, emulating the operation of much longer shotgun microphones.

### Functional and Durable

At just 250mm/10" long, the CS-2 weighs only 110grams/3.8 oz., making it lightweight and ideal

for camera-mounted or boom pole operations. An external brass chassis markedly increases durability, while the PPS (Poly-gold Phenylene Sulfide) diaphragm membrane provides optimum resistance to changes caused by adverse temperature and humidity.

### Acoustic Quality

An extended length audio tube provides maximum directivity and reach while still preserving Sanken's renowned rich and natural tone. Since windscreens used in field recording cause loss of high frequencies, the CS-2's High Boost Switch automatically compensates for this factor.



The world's most original microphone maker

# CS-2 Compact shotgun mic with long reach and rich, natural tone

## Specifications:

Transducer	DC biased condenser
Directivity	Low to Mid: Super Cardioid Mid to High: Lobar
Sensitivity	-24dB (63mV) (0dB = 1V/Pa)
Equivalent noise level (A weighted)	15dB SPL
Max SPL(1% THD)	130dB SPL
Output impedance(1kHz)	120 ohms
High Boost Switch	+3dB / 8kHz
Phantom Powering	+48Vdc ± 4V
Current consumption	3.5 mA
Weight	110 g
Surface finish	Matte black
Connector	XLR-3-12C(M) equivalent (1: GND, 2: Hot, 3: Cold )

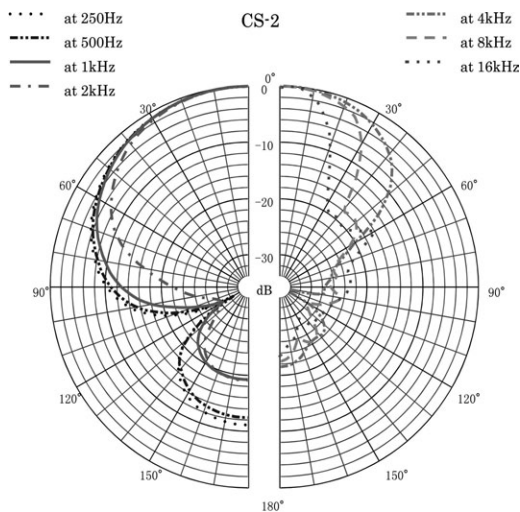
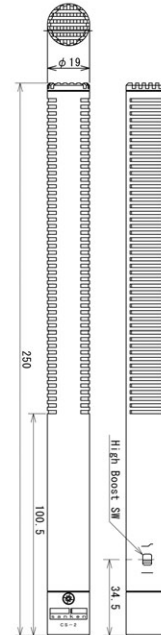

## Frequency Response

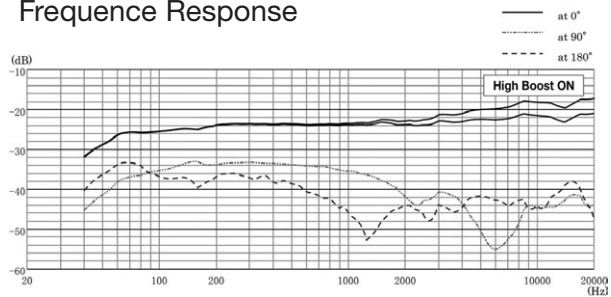

## Frequency Response with Wind Screen & Jammer

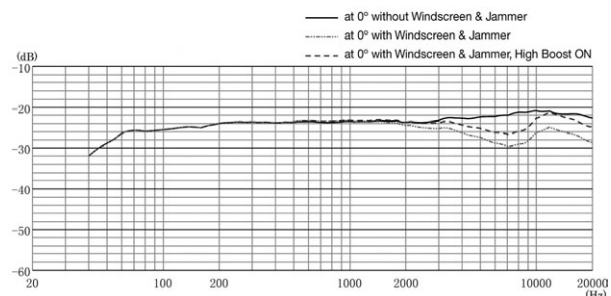

Western Hemisphere Distributor • 1155 N. La Brea Ave. • West Hollywood, CA 90038  
323-845-1171 • fax: 323-845-1170 • sales@plus24.net • www.plus24.net

We reserve the right to improve or alter product design and specifications without notice or obligation.